

TREASURE ISLAND 1700

(SUBSINO CASINO GAME – XVGA SERIES)

This game takes a theme you already love – Treasure Island - to the next level with XVGA 5-reels and 25-lines of excitement.

State-of-the-art graphics promote exciting 3D effect.
High resolution producing sharper pictures.
Remarkable & Swanky music/ sounds.
Clever player interaction.



Main Game

HOW TO PLAY

- Insert coin(s) or bill(s).
- Press [5 lines] or [10 lines] or [15 lines] or [20 lines] or [25 lines] to choice the lines you would like to play.
- Press [Bet] to bet one credit for each select line. Or, press [Max Bet] for max bet and begin.
- Then press [Start] button to spin the reels. Press [Stop1], [Stop2], [Stop3], [Stop4] or [Stop5] to stop the reel or [Start] button again to stop all reels.
- When you have any win combination, you win. Press [Take Score] to take winning score into Credit, or press [Double Up], [Half Double] or [Re-Double] to play Double Up game. If Double-Up function is disabled, the system will take scores automatically.
- Press [Help] to check the result of last game and relative game information. Or, select Denomination value when the function is available.



Double-Up

GAME FEATURES

- **CAPTAIN HOOK SYMBOL:** Captain Hook is wild as joker to replace any symbols.
- **FREE PLAY:** Land three or more Corsair symbols anywhere on the reel triggers the fever. It's time for serious free-spin fun, and regular play for the award and may multiply by 2, 3, 4 or 5.

3 CORSAIRS; 4 CORSAIRS; 5 CORSAIRS:

Free Play 7 times; 12 times; 20 times

- **BONUS GAME:** Initiated when over 3 progressive **Treasure Island** symbols land on a played line, and starting with Bonus game. Following two bonus games can select:

Roulette Fever - The Bonus is to match between the symbol of 4 reels and side running lamp. Any hit is the award as the Pair.

Treasure Chest - You'll receive 8 secret chests and select the award by you. Select again till hidden weapon or poison smoke is found.



Roulette Fever



Treasure Chest

INSTALLATION

● MAIN PCB

- 1) Make sure you have powered-off game.
- 2) Mount Treasure Island 1700 PC Board on the cabinet.
- 3) Connect 36pin and 10 pin edge connector of the cabinet to Edge connectors (36pin & 10 pin) of Treasure Island 1700 main PCB. Refer Page 11 for the diagram of Connector.

● MONITOR

- 1) Make sure the monitor (CRT/LCD/TFT) supports **1024x768 resolution**.
- 2) Connect monitor connector to the monitor socket (VGA D-Sub) of Treasure Island 1700 main PCB.

● SPEAKER

- 1) Audio Amplifier of hardware is newest powerful stereo Amplifier. It uses 2 set separate speakers for Audio Out. Connect **two speakers to (R+:R-) and (L+:L-)** of J3.
- 2) **Don't connect any of "Audio Out" to Ground (GND) or link directly the speaker to Ground. In the case of wrong Ground linkage, it will cause PC Board (hardware) damage.**

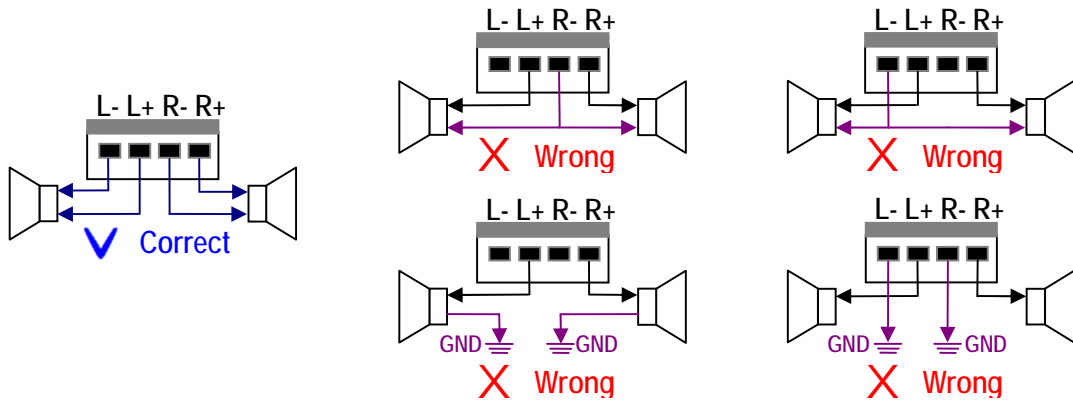
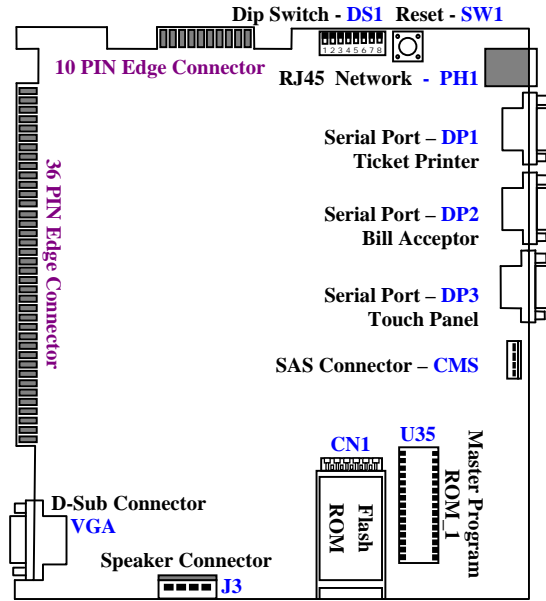

- 3) The **20watt, 8 ohm speaker and more** is recommended. If the power of speaker doesn't enough, the "distortion" may find when audio out.

● TOUCH PANEL

- 1) It's optional and shows relative function automatically after connect.
- 2) Make sure the panel is **3M Microtouch panel or compatible**, and connect to **DP3 – Touch Panel port**. The screen will show relative buttons and function this moment.
- 3) Calibrate: Press [Test/ Setup] on the cabinet to go to "Test/ Setup Mode" and select "Touch Screen Calibrate". Touch a Cross symbol for two times to calibrate.

● **BILL ACCEPTOR (SERIAL TYPE)**

- 1) The game is available to use both pulse and serial type of Bill Acceptor.
- 2) If use serial type of Bill Acceptor as JCM WBA/ UBA or compatible, adjust Dip Switch Dip#1 to ON and link the connector of Bill Acceptor to **DP2** – Bill Acceptor.

● **TICKET PRINTER AND SAS PROTOCOL**

Both Ticket Printer (**DP1**) and SAS Protocol (**CMS**) are unavailable in the version, and supports in specific version only.

● **CONTROL PANEL**

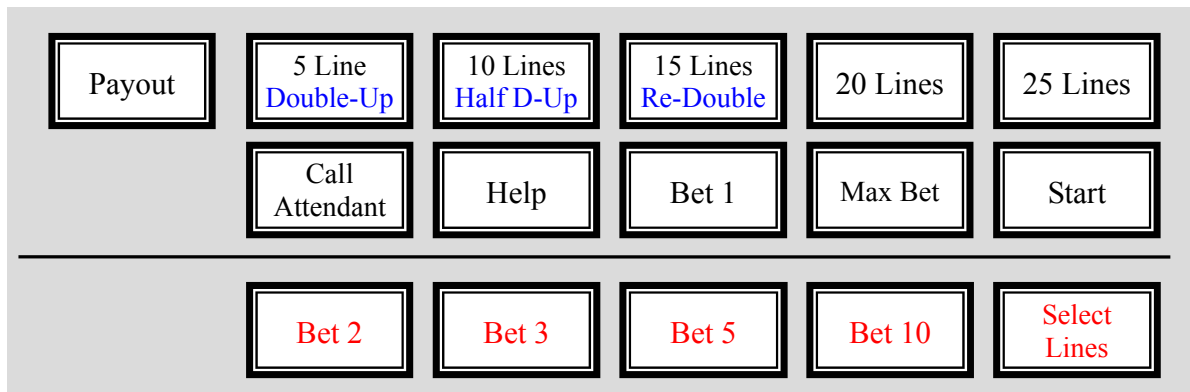

Establish above buttons on the panel. Refer the page of Connector Diagram.

▶ **5 LINES/ STOP1/ DOUBLE, 10 LINES/ STOP2/ HALF DOUBLE, 15 LINES/ STOP3/ RE-DOUBLE, 20 LINES/ STOP4, 25 LINES/ STOP5**

- 1) Choice the lines (5 Lines, 10 Lines, 15 Lines, 20 Lines or 25 Lines) for playing.
- 2) Stop the reel by Stop1, Stop2, Stop3, Stop4 and Stop5.
- 3) Choice D-Up Mode (Double, Half Double or Re-Double) and Play (Stop2 to Stop5).

▶ **START/ ALL STOP/ TAKE SCORE**

- 1) Begin the game and again to stop all reels.
- 2) Take winning score after won.

▶ **BET 1**: To bet one credit per push for each select line.

▶ **BET 2, BET3, BET5, BET10, SELECT LINES**:

- 1) These are extra Bet buttons and optional by the operator. It's to bet 2, 3, 5 or 10 credit per push for each select line.
- 2) Select Lines: It's an extra button to select lines in order.

▶ **MAX BET**: To wager max value of bet and start the game.

▶ **HELP**: Check last game and game features before the player bets.

● **POWER ON AND CHECK**

- 1) After you do all of above, please power on the game. Check +5V DC on main PCB side. The voltage between +4.95 to 5.05V DC is good.
- 2) Press [Test/ Setup] on the cabinet to go to “Test/ Setup Mode”.

- 3) Refer Page 4 to 7 of “Test/ Setup Mode” to set each setting.
- 4) Also, check each function and movement in Test/ Setup Mode. (All buttons & lamps, TV size and color adjustment ... etc.)
- 5) Please refer to page 10 of “Troubleshooting” or “Error” if you have any problems or malfunctions.

TEST AND SETUP

If you need to check the condition of the game circuitry, controls or set system value, you can use the Test/ Setup Mode.

Power ON and Press [Test/ Setup] key will go to the mode, as right.

- Moving the bar by pressing [Stop1] button. After choosing one of the contents with the bar, press the [Stop5] to enter.
- Press [Start] to exit and back to game mode of main screen. In the case, the value you adjusted would available instantly, which don't necessary to turn off the power.

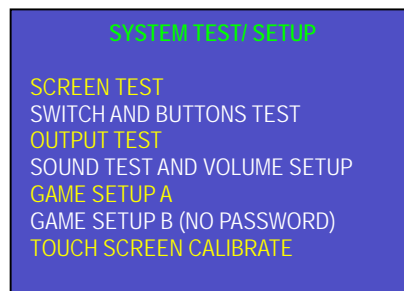

1) SCREEN TEST

- Use this screen to check the color of monitor and the size of pictures.
- The color bands in the center should be Red, Green, Blue and White from left to right.
- The Cross Hatch test pattern has a white grid on a black background. The check as follows:
 - ▶ The grid line should be straight, and the lines should not have excessive pincushion or barrel distortion.
 - ▶ “Out” line of grid line is same size as “Out” line of game screen, which should able to be seen without overflow of grid lines on screen.
- If the screen does not match above description, adjust the monitor as described in the monitor’s manual.
- Press the [Start] button to back main menu.

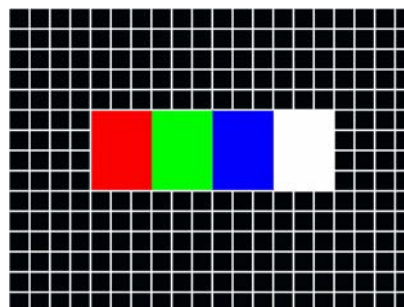

2) SWITCH AND BUTTONS TEST

Use this screen to check the buttons and the switch in this game.

- To check the functioning of each button and switch, activate it and watch the corresponding “OFF” letters change to “ON”. If the “ON” and “OFF” letters don’t appear correctly, check the hardness connections and switches.
- Press the [Start] button to back main menu.

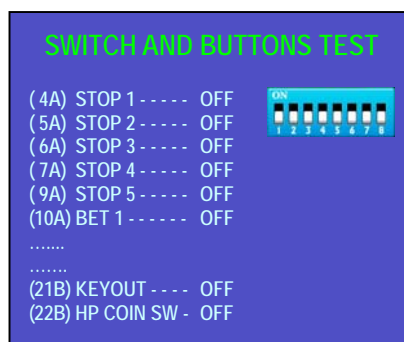

3) OUTPUT TEST

Use this screen to check the lamp of buttons in this game.

- To check the functioning of each output, including Counters and lamp of button. Press [Stop1] to move and press [Stop1] to test as watch the corresponding lamp ON.
- Counters, Bill Inhibit, Coin Inhibit and HP Full Out are to test the action, no lamp.
- Press the [Start] button to exit.

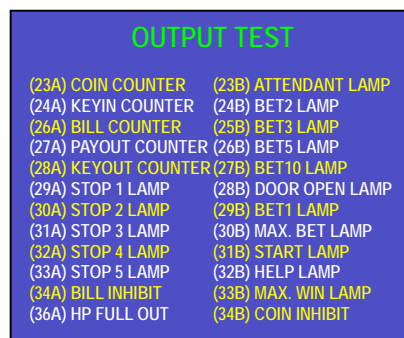

4) SOUND TEST AND VOLUME SETUP

Use this screen to check all game sounds and setup the volume as soft volume control.

- Adjust the volume by pressing [Stop1] to decrease and [Stop2] to increase.
- Choice a sound by pressing [Stop3] button (previous) or [Stop4] button (next), and the machine will make a sound in the moment.
- Press the [Start] button to back main menu.

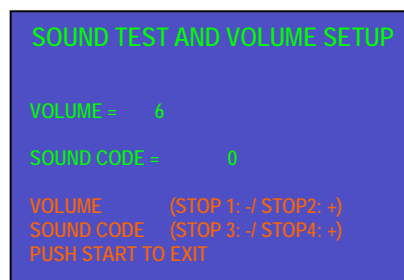

5) GAME SETUP A

The setup items are important and operated by important person as owner only. The password is necessary before enter the screen of Game Setup A.

The default value is 111111 (six 1) and enable to change in same password screen.

[Stop1] button for 1; [Stop2] button for 2; [Stop3] button for 3;
 [Stop4] button for 4; [Stop5] button for 5;

When the password input with correct, “OK!” is shown on the screen. To change new password, press [Max Bet] button and input new password as you want. Or, press [Start] button to enter screen of Game Setup.

Use the screen to manually adjust the game setting.

- Moving the bar by pressing [Stop1] button.
- Select the setting value by pressing [Stop5] button.
- Press the [Start] button to back main menu. In the case, the value you adjusted would available instantly, which don't necessary to turn off the power.



Contents	Setting Selection (Underlined in setting selection are default settings)
DENOMINATION	<u>DISABLE</u> , ENABLE
COIN	1, 2, <u>5</u> , 10, 20, 25, 50, 75, 100, 200, 300
KEYIN	1, 2, <u>5</u> , 10, 20, 25, 50, 75, 100, 200, 300, 500
PAYOUT	1, 2, <u>5</u> , 10, 20, 25, 50, 75, 100, 200, 300
KEYOUT	1, 2, <u>5</u> , 10, 20, 25, 50, 75, 100, 200, 300, 500
BILL IN	1, 2, <u>5</u> , 10, 20, 25, 50, 75, 100, 200, 300, 500
MIN. BET	1, <u>5</u> , 10, 25, 50, 100
MAX. BET	100, 200, 250, 300, 400, 500
WIN RATE	90, 91, 92, 93, 94, 95, 96, 97, 98
GAME LIMIT	5000, 10000, 20000, 30000, 40000, <u>60000</u> , 80000, 100000, 150000, 200000
WIN RATE WAVE	<u>NORMAL</u> , HIGH
MONEY TYPE	US, OTHER
DOUBLE FUNCTION	<u>ENABLE</u> , DISABLE
HALF-DOUBLE	<u>ENABLE</u> , DISABLE
RE-DOUBLE	<u>ENABLE</u> , DISABLE
DOUBLE RATE	91, 92, 93, 94, 95, 96, 97, 98
DOUBLE LIMIT	5000, 10000, 20000, <u>30000</u> , 40000, 50000, 60000, 80000, 100000

- ▶ Denomination: To open Cash value and operated with Credit value.
- ▶ Coin: Adjust how many credits per insert coin.
- ▶ Keyin: Adjust how many credits per Keyin.
- ▶ Payout: Adjust how many credits per pay coin.
- ▶ Keyout: Adjust how many credits per pay Step when Keyout.
- ▶ Bill In: Adjust how many credits per Bill signal.
- ▶ Min Bet: Adjust how many min bets to start the game.
- ▶ Max Bet: Adjust how many max bets can bet at one play.
- ▶ Win Rate: Adjust total rate % of game.

The win Rate is calculated and defines as follows:

$$\text{Win Rate} = \frac{\text{Total Won Score}}{\text{Total Played Score}}$$

Since this is quite different from some games, which defined the rate as “Coin Out” divided by “Coin In” (Usually call Payout Rate). You shouldn't set the win rate at the same value used in the games. In our experience, the ideal Win Rate is 94%.

Please don't RESET except necessary. To stabilize the rates, the game should operate a period (more long, more steady) for the balance as setup.

- ▶ Game Limit: Adjust how many credits game can hold.
- ▶ Win Rate Wave: It's to assign the prizes and rate. Big wave has more big prizes and focus more win or lose. Small wave has more small prizes and rate with more steady.
- ▶ Money Type: To select the bill and use for denomination.
- ▶ Double Func.: Play D-Up game when Main Game won. The play score in D-Up is winning score in main game.
- ▶ Re-Double: The play score in Double Up is twice winning score in main game.
- ▶ Half Double: The play score in Double Up is a half of winning score in main game.
- ▶ Double Rate: The rate of D-Up game and defines as Win Rate.
- ▶ Double Limit: To limit the winning score in Double Up. The system will take the score automatically when winning score is over Double Limit.

6) GAME SETUP B (NO PASSWORD)

The setup items are general ones and can operate by the staff in field. The password is unnecessary for the function of Game Setup B.

Use the screen to manually adjust the game setting.

GAME SETUP	
TOUCH SCREEN	DISABLE
DEMO MUSIC	ON
DEMO SHOW	ON
KEYOUT TYPE	ZERO
MAX. PAY TOKENS	FREE
BILL INHIBITION	N.C
HOPPER SW TYPE	N.O.
.....	

Contents	Setting Selection (Underlined in setting selection are default settings)
TOUCH SCREEN	ENABLE, <u>DISABLE</u>
DEMO MUSIC	<u>ON</u> , OFF
DEMO SHOW	<u>ON</u> , OFF
KEYOUT TYPE	<u>ZERO</u> , REST
MAX. PAY TOKENS	200, <u>300</u> , 400, 500, FREE
BILL INHIBITION	<u>N.C.</u> , N.O.
HOPPER SW TYPE	<u>N.C.</u> , N.O.
BILL ACCEPTOR	<u>JCM</u> , ICT
AUTO PLAY	<u>ENABLE</u> , DISABLE
HOPPER	<u>OFF</u> , ON

- ▶ Touch Screen: To enable or disable Touch Function.
- ▶ Demo Music: To enable or disable demo music.
- ▶ Demo Show: To enable or disable demo function.
- ▶ Keyout Type: Adjust Keyout should take to 0 (zero) or under one Keyout value (rest).
- ▶ Max Pay Tokens: Adjust max coins are paid, which to avoid the hopper empty.
- ▶ Bill Inhibition: For Bill Acceptor. N.C. - Normal close (low), N.O. – Normal Open (Hi).
- ▶ Hopper Sw. Type: For Hopper. N.C. - Normal close (low), N.O. – Normal Open (Hi).
- ▶ Auto Play: To enable or disable play automatically.

7) TOUCH SCREEN CALIBRATE

The item appears only when Touch Panel was connected. It's to calibrate the touch position. Enter the item and touch a Cross symbol for two times to calibrate.

8) DIP SWITCH FUNCTION

Except Screen Setup, some of functions are defined and setup from Dip Switch of PC Board, as follows:

DIP SWITCH		1	2	3	4	5	6	7	8
BILL ACCEPTOR	Serial Pulse	ON OFF							
DOOR OPEN	N.C. N.O.		ON OFF						
HOPPER PULSE (Milli-Second)	30 ms 40 ms 50 ms 60 ms			OFF ON OFF ON	OFF OFF ON ON				

BOOK

Press [Book] button to enter Book screens. Press [Stop5] to enter next page and [Stop1] for previous page. Press [Start] button to back normal game.

First Page



The page shows the records from last “check out” till now.

Total Times: Total played times.

Total Played: Total played score.

Total Won: Total won score.

“Check Out”: To clear this page. Please refer Page 9, Reset function for Clear Current Record Only.

Second Page



The Score column of top form shows the score of Coin, Payout, Keyin, Keyout, Bet, Won and Net.

The Counter column shows "System Counters". It doesn't able to clear by anyway and affected by Reset function, which to compare relatively with machine's mechanical counters when “check out each time”.

Total/Main/Double Played & Total/Main/Double Won Played scores and Won scores in Total/ Main game/ Double game.

Total/Main/Double Play Times & Total/Main/Double Win Times

Played times & Win times in Total/ Main game/ Double game.

Free Play/Treasure Chest/Roulette Fever: It shows win times and win score of bonus game.

Power Times: The times of Power ON.

Third & Fourth page: Both pages shown winning times of each prize.



RESET (Clear)

● CLEAR ALL

Turn off the power. Turn on [Book] and [Setup] key simultaneously and then turn on the power. (If [Book] or [Setup] make by the buttons, you should press without release.)

The screen will show "System Reset", which means all of Book data have cleared and game setup values have changed to default value. ("System Counters" in the second page of Book remain unchanged and cleared to zero.).

- ▶ RESET button on the board is unavailable in current version.
- ▶ You should do RESET if you change the Master Rom (Rom_1).
- ▶ Don't forget to do RESET after changed the Win Rate.

● CLEAR CURRENT RECORD ONLY (CHECK OUT)

Turn on [Book] Key (or press [Book] button) to enter first page of Book for Current Record. Press [Stop2] and [Stop3] button simultaneously to clear the data of this page. The total records (second page) for from initial operation remain unchanged by this function.

MACHINE LAYOUT

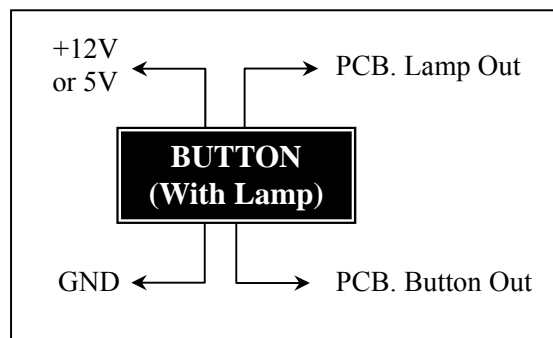
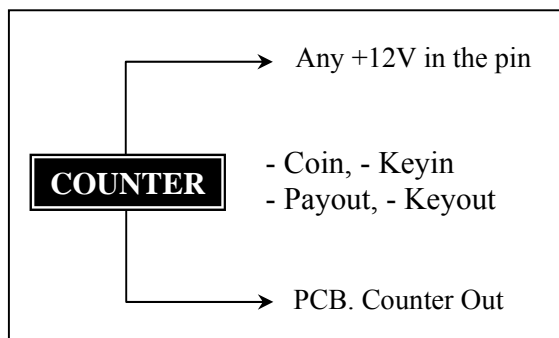
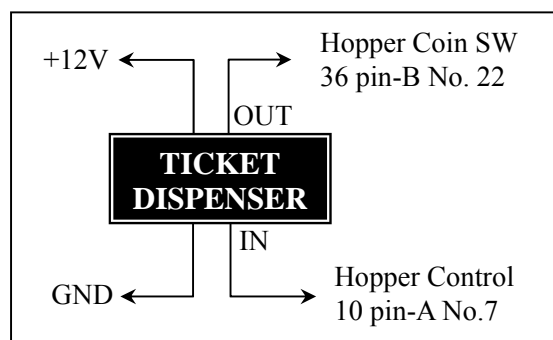
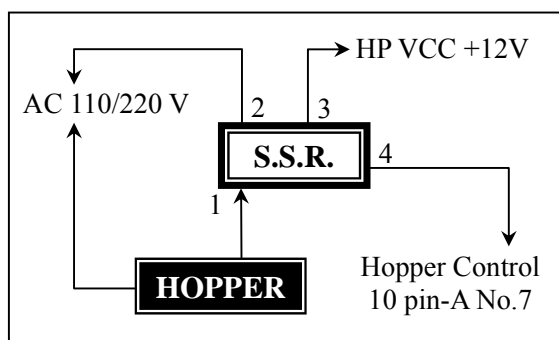

ICT BILL ACCEPTOR - CONNECTOR – CN#1

PIN#1(Red)	- To PCB +12V
PIN#2(Orange)	- To PCB GND
PIN#3(Yellow)	- To PCB +12V
PIN#4(Green)	- To PCB BILL GND (36 Pin Side A, #34)
PIN#5(Blue)	- To PCB BILL (36 Pin Side A, #15)
PIN#6(Purple)	- Unused

ERROR MESSAGE

MESSAGE	DESCRIPTION
System Error	The system may a little confusion instantly. Please do Reset function.
Coin Jam	Power off. Remove the jammed coin from coin selector and power on again. For general error (without jam), press directly “Reset Error” button.
Hopper Jam	Power off. Remove the jammed coin from the hopper and power on again. For general error (without jam), press directly “Reset Error” button.
Hopper Empty	Hopper without Coins/Tokens. Please power OFF and insert Coins/Tokens then power ON again.

TROUBLESHOOTING

SITUATION	FIX
Coin Error	Check coin switch, coin selector and wire wrong.
No sound	<ul style="list-style-type: none"> ● Check the wire of (R+:R-) and (L+:L-) of J3. Two Speaker GND need to be wired separately and don't use same ground. ● Check “Volume setup” on setup page whether close or not.
The counter doesn't work	Check the +12V DC (or +5V DC) line of the counter wire. The wires sometimes are not linked together 10 pin edge connector side of hardness. Please re-wire.
Malfunction of the button, switch and lamps	Check the GND wire. The button, Switch GND has to wire with common GND. Or, check micro switch of button is too old or dirty and the lamp whether out of order.
Coin or Keyin with wrong value	<ul style="list-style-type: none"> ● Check Coin and Keyin wire. Keyin SW port may wire to Coin SW or Bill Acceptor and so on. Please re-wire to correct port. ● Check Game Setup.
Test/ Setup unavailable	Check connection of GND wire between “Test/ Setup” line and common GND line. The GND wire needs to connect with other common GND line.
The Monitor unregulated or Wavy	Adjust the brightness, size and so on as described in the monitor's manual.
Touch Screen doesn't react	<ul style="list-style-type: none"> ● Check the connector of touch screen link exactly to DP3 – Touch Panel port. ● Check “Game Setup B” of Test/ Setup Mode”, Touch Screen set to “Enable” item. And then, power Off and On again to ensure the setup is available.

CONNECTOR DIAGRAM

Treasure Island 1700 (Standard)

COMPONENT SIDE A	36 PIN	SOLDER SIDE B
	1	
	2	
	3	
5 Lines	4	Bet 2
10 Lines	5	Bet 3
15 Lines	6	Bet 5
20 Lines	7	Bet 10
Select Lines	8	
25 Lines	9	
Bet	10	
Max. Bet	11	
Attendant	12	
Start	13	
Help	14	
Bill	15	
Clear Error	16	
	17	
Coin	18	Keyin
Door Alarm	19	
Book	20	Test/ Setup SW
Payout	21	Keyout SW
HP Full SW	22	Hopper SW ⁽¹⁾
Coin Counter	23	Attendant Lamp
Keyin Counter	24	Bet 2 Lamp
	25	Bet 3 Lamp
Bill in Counter	26	Bet 5 Lamp
Payout Counter	27	Bet 10 Lamp
Keyout Counter	28	Door Open Lamp
5 Lines Lamp	29	Bet Lamp
10 Lines Lamp	30	Max Bet Lamp
15 Lines Lamp	31	Start Lamp
20 Lines Lamp	32	Help Lamp
25 Lines Lamp	33	Max. Win Lamp
Bill Inhibit	34	Coin Inhibit
HP Full Out	35	Select Lines Lamp
GND	36	GND

COMPONENT SIDE A	10 PIN	SOLDER SIDE B
GND	1	GND
GND	2	GND
+5V	3	+5V
+5V	4	+5V
+12V	5	+12V
	6	
⁽²⁾ Hopper Control	7	HP VCC ⁽³⁾
	8	
GND	9	GND
GND	10	GND

⁽¹⁾ HP Coin SW: Out signal for Hopper

⁽²⁾ HP Control: In signal for Hopper

⁽³⁾ HP VCC - (DC+12V)

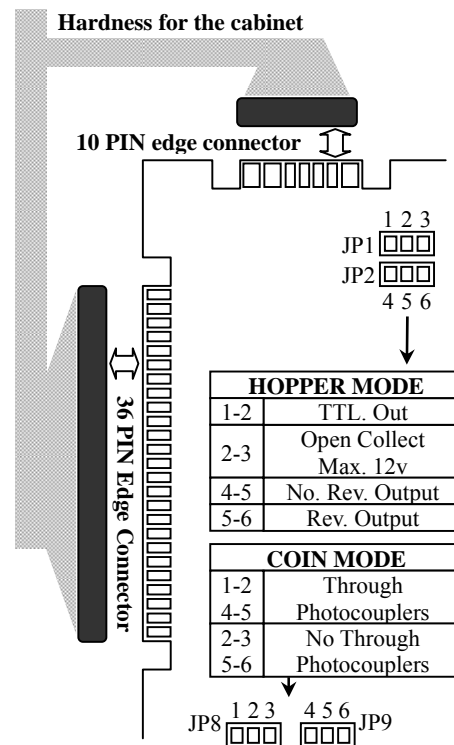

- Clear Error button: To correct instantly the message of “Coin Error”, “Coin Jam” and “Hopper Jam” etc after fix.